

**Housings for Dry Filter Elements / Static Vanes System**  
**For On-Highway, Off-Highway and Stationary Applications.**

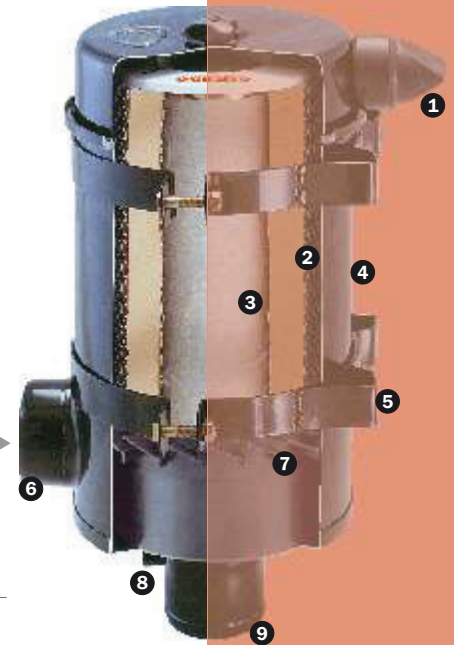

- 1 Evacuator Valve
- 2 Primary Element
- 3 Safety Element
- 4 Housing
- 5 Mounting Band
- 6 Air Intake
- 7 Static Vanes
- 8 Restriction Indicator Tapping Point
- 9 Outlet Pipe (to the engine)

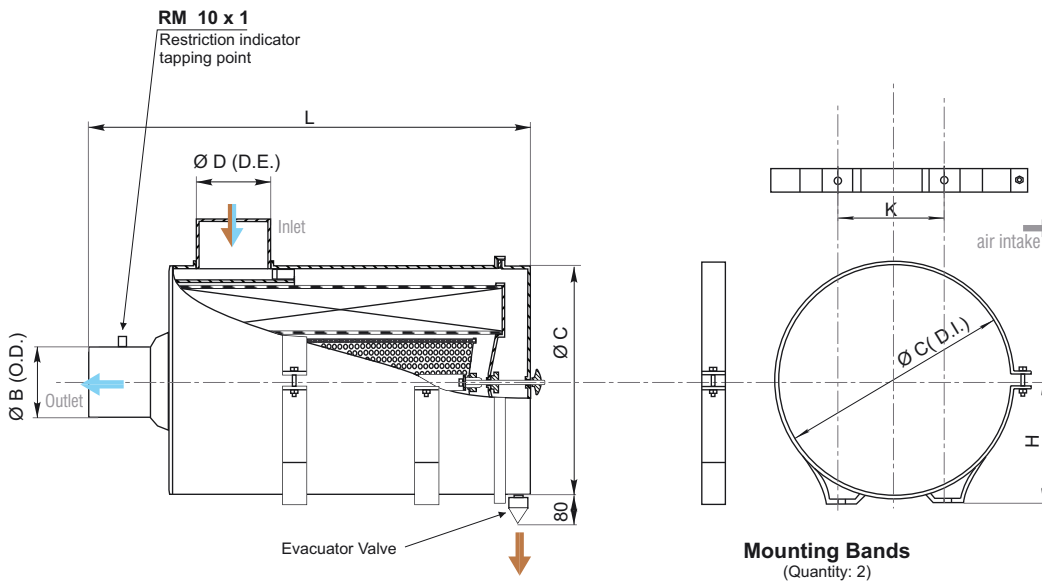
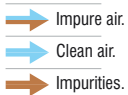

| MODEL | Airflow Range  | Horsepower Range               | Weight<br><i>With filter elements</i> | Dimensions         |                   |                    |                    |                   | Primary Element   | Safety Element |          |
|-------|--|--------------------------------|---------------------------------------|--------------------|-------------------|--------------------|--------------------|-------------------|-------------------|----------------|----------|
|       |  |                                |                                       | L                  | K                 | H                  | Ø C                | Ø B               |                   |                | Ø D      |
| KL 4  | 1.5 a 4.5 m <sup>3</sup> /min<br>(53 a 159 CFM)      | 30 a 80 HP<br>(22 a 60 KW)     | 3.80 kg<br>(8.40 lbs)                 | 385 mm<br>(15.16") | 120 mm<br>(4.72") | 98 mm<br>(3.86")   | 167 mm<br>(6.57")  | 63 mm<br>(2.50")  | 63 mm<br>(2.50")  | EP 070         | ES 070   |
| KL 6  | 4.5 a 6.0 m <sup>3</sup> /min<br>(159 a 212 CFM)     | 80 a 90 HP<br>(60 a 67 KW)     | 4.90 kg<br>(10.79 lbs)                | 425 mm<br>(16.73") | 120 mm<br>(4.72") | 114 mm<br>(4.49")  | 198 mm<br>(7.80")  | 70 mm<br>(2.75")  | 76 mm<br>(3")     | EP 080         | ES 080   |
| KL 8  | 6.0 a 8.0 m <sup>3</sup> /min<br>(212 a 282 CFM)     | 90 a 120 HP<br>(67 a 90 KW)    | 5.30 kg<br>(11.70 lbs)                | 445 mm<br>(17.52") | 120 mm<br>(4.72") | 126 mm<br>(4.96")  | 216 mm<br>(8.50")  | 76 mm<br>(3")     | 76 mm<br>(3")     | EP 120         | ES 120   |
| KL 12 | 8.0 a 12.0 m <sup>3</sup> /min<br>(282 a 423 CFM)    | 120 a 160 HP<br>(90 a 120 KW)  | 7.50 kg<br>(16.50 lbs)                | 478 mm<br>(18.82") | 120 mm<br>(4.72") | 146 mm<br>(5.75")  | 253 mm<br>(9.96")  | 102 mm<br>(4")    | 102 mm<br>(4")    | EP 180         | ES 180   |
| KL 15 | 12.0 a 15.0 m <sup>3</sup> /min<br>(423 a 529 CFM)   | 160 a 180 HP<br>(120 a 134 KW) | 9.95 kg<br>(21.92 lbs)                | 480 mm<br>(18.90") | 140 mm<br>(5.51") | 146 mm<br>(5.75")  | 267 mm<br>(10.51") | 102 mm<br>(4")    | 102 mm<br>(4")    | EP 220         | ES 220   |
| KL 18 | 15.0 a 18.0 m <sup>3</sup> /min<br>(529 a 635 CFM)   | 180 a 210 HP<br>(134 a 157 KW) | 12.50 kg<br>(27.55 lbs)               | 548 mm<br>(21.57") | 140 mm<br>(5.51") | 161 mm<br>(6.34")  | 290 mm<br>(11.42") | 102 mm<br>(4")    | 114 mm<br>(4.5")  | EP 240         | ES 240   |
| KL 20 | 18.0 a 20.0 m <sup>3</sup> /min<br>(635 a 706 CFM)   | 210 a 250 HP<br>(157 a 187 KW) | 14.10 kg<br>(31.06 lbs)               | 528 mm<br>(20.79") | 140 mm<br>(5.51") | 175 mm<br>(6.89")  | 319 mm<br>(12.56") | 133 mm<br>(5.25") | 133 mm<br>(5.25") | EP 250         | ES 250   |
| KL 21 | 20.0 a 21.0 m <sup>3</sup> /min<br>(706 a 741 CFM)   | 240 a 280 HP<br>(179 a 209 KW) | 15.40 kg<br>(33.90 lbs)               | 608 mm<br>(23.94") | 140 mm<br>(5.51") | 175 mm<br>(6.89")  | 319 mm<br>(12.56") | 130 mm<br>(5.12") | 133 mm<br>(5.25") | EP 260         | ES 260   |
| KL 28 | 21.0 a 28.0 m <sup>3</sup> /min<br>(741 a 988 CFM)   | 280 a 320 HP<br>(209 a 239 KW) | 18.15 kg<br>(40.00 lbs)               | 591 mm<br>(23.27") | 200 mm<br>(7.87") | 220 mm<br>(8.66")  | 392 mm<br>(15.43") | 152 mm<br>(6")    | 152 mm<br>(6")    | EP 310/P       | ES 310/P |
| KL 35 | 28.0 a 35.0 m <sup>3</sup> /min<br>(988 a 1235 CFM)  | 320 a 380 HP<br>(239 a 283 KW) | 21.00 kg<br>(46.25 lbs)               | 631 mm<br>(24.84") | 200 mm<br>(7.87") | 258 mm<br>(10.16") | 442 mm<br>(17.40") | 152 mm<br>(6")    | 152 mm<br>(6")    | EP 350         | ES 350   |
| KL 43 | 35.0 a 43.0 m <sup>3</sup> /min<br>(1235 a 1517 CFM) | 380 a 450 HP<br>(283 a 335 KW) | 35.70 kg<br>(78.65 lbs)               | 723 mm<br>(28.46") | 180 mm<br>(7.09") | 268 mm<br>(10.55") | 457 mm<br>(17.99") | 152 mm<br>(6")    | 152 mm<br>(6")    | EP 430         | ES 430   |

Notes: 1) In normally aspirated engines the model selection by horsepower range is just a recommendation. 2) In turbocharged or turbo-aftercooled engines the correct model selection is based on the maximum air flow. 3) For particular applications you have a complete line of installation accessories.



## **Housings for Dry Filter Elements / Static Vanes System For On-Highway, Off-Highway and Stationary Applications.**

# **DUST BUSTER**

### **PRODUCTS**

These Air Filters have a steel housing with a static vane first stage. Primary and safety filter elements are standard. This range is a three-stage air cleaner system with universal mounting bands. The standard tube style inlet is suitable for use with an DUSTBUSTER Air Precleaner.

DUSTBUSTER Air Filters are powder coated for a durable, corrosion-resistant finish. Air flows range from 53 to 1517 CFM (1.5 to 43.0 m<sup>3</sup>/min). Complete specifications are provided on the previous page.

### **HOW THEY WORK**

Air flows through static vanes (plastic or metal) which causes the air to spin. Centrifugal force separates the heaviest impurities (dust, dirt, insects and other debris) from the air stream. These contaminants are discharged automatically through an integral evacuator valve. Only purified air flows to the air filter elements (primary and safety stages of filtration). These elements retain the 99,9% of the contaminants which were not eliminated in the first stage. Then clean air flows to the engine through the outlet pipe.

### **FEATURES AND BENEFITS**

- The first stage (static vanes and evacuator valve) removes larger contaminants from the air before entering the air filter elements.
- Extend engine air filter life.
- Reduce down time.
- Compact, easy to install.
- Wide range of applications.
- Steel housing, black powder coat.
- High air flow, low differential design.
- Horizontal mounting.
- Standard element replacement.
- Safety element is standard.
- Restriction indicator port is standard.
- Suitable for use with an DUSTBUSTER Air Precleaner.

### **APPLICATIONS**

These Air Filters are designed to be connected to the air intake of the gasoline, diesel or compressed natural gas engine. Their applications include agricultural machinery; earth-moving equipment; stationary engines; generator sets; trucks; busses and recreational vehicles; material handling equipment; snow removal equipment and street sweepers.

